

SPRAY BOOTH SB-88

This spray booth is used to remove fumes caused by spray painting.
The fumes will be filtered and removed by the exhaust pipe to an outside area

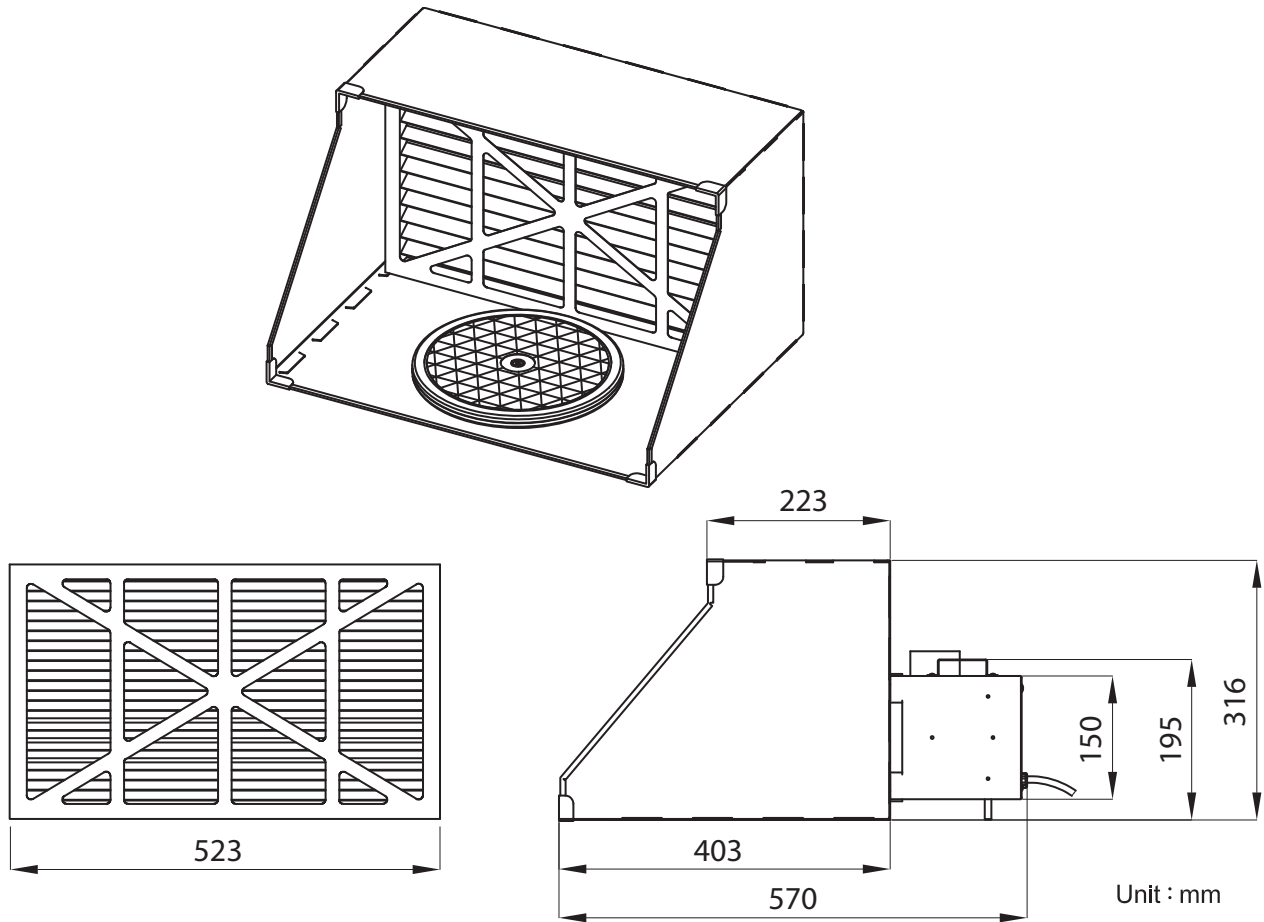

Warning:

For Europe only:

- The appliance shall not be used by persons (including children aged 8 years and above) who have reduced physical, sensory, or mental capabilities unless they are under the supervision or instruction of a competent adult.
- Children shall not play with the appliance.
- Cleaning and maintenance of the appliance may only be conducted by a child when he/she is under the direct supervision of a competent adult.

For outside Europe :

- The appliance shall not be used by persons (including children) who have reduced physical, sensory, or mental capabilities unless they are under the supervision or instruction of a competent adult.
- Children shall not play with the appliance.



Attention:

1. Do not plug in during assembly.
2. During operation, try to place objects at the center of the booth.
3. After each use, keep the exhaust fan running for another 6~12 minutes, which will effectively clean out most of the remaining paint particles in the air.
4. To maintain the safety of electrical appliances, turn off the power switch and pull out the power cord from the receptacle when the exhaust fan is not in use.
5. Immediately replace filters that have accumulated a heavy coat of paint or color. The usable lifetime of a filter shall vary depending on the frequency and manner in which the spray booth is used.
6. If the power cord is damaged, it must be replaced by the manufacturer, its service agent, or similarly qualified technicians to avoid hazards.
7. Direct the exhaust pipe outdoors.
8. The spray booth must be used in a well ventilated area.

Note: Not intended for use with Hazardous Materials, Flammable or Explosive Paints or Materials.

SPRAY BOOTH SB-88

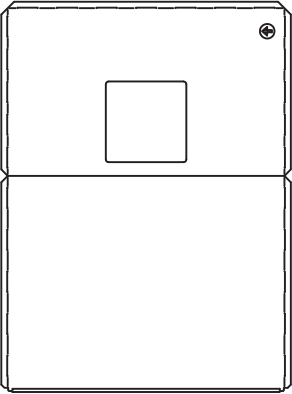
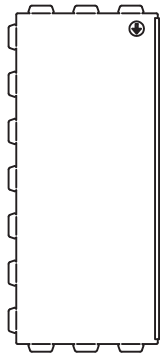
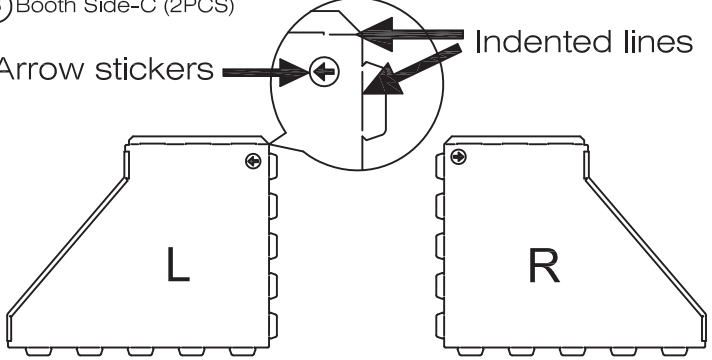
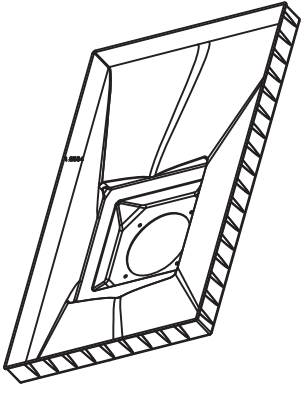
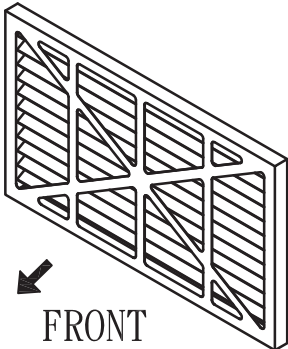
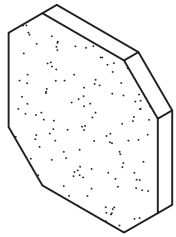
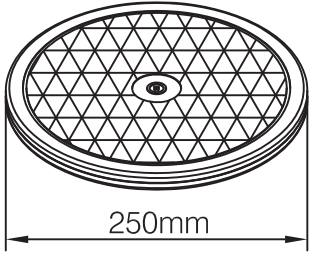
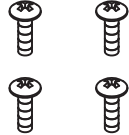
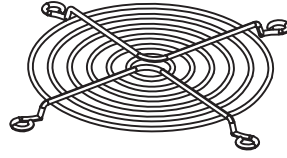
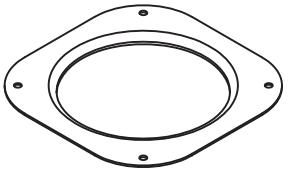
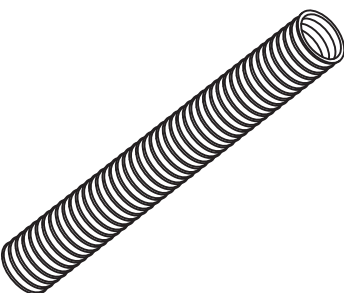
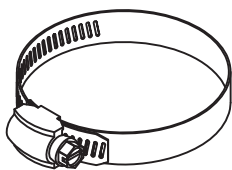
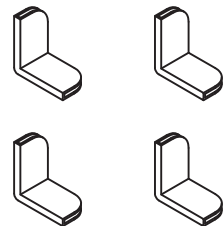
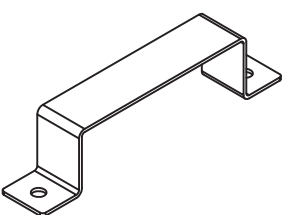
Part list

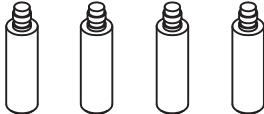
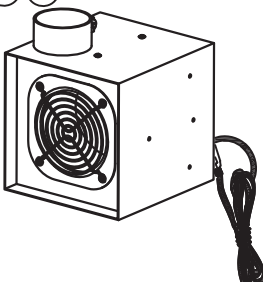
<p>① Main Booth Side-A (1PCS)</p> 	<p>② Booth Side-B (1PCS)</p> 	<p>③ Booth Side-C (2PCS)</p>  <p>NOTE: Please differentiate the left and right booth sides as well as the bending direction according to the indented lines and arrow stickers at the front.</p>	
<p>④ Air Intake Hood (1PCS)</p> 	<p>⑤ Filter 1 (2PCS)</p> 	<p>⑥ Filter 2 (2PCS)</p> 	
<p>⑦ Rotating Plate (1PCS)</p>  <p>250mm</p>	<p>⑧ Set Screw for Binding Piece (long) (4pcs) (included in Exhaust Fan Set ⑰)</p> 	<p>⑨ Fan Cover (1PCS) (included in Exhaust Fan Set ⑰)</p> 	<p>⑩ Binding Piece (1PCS)</p> 
<p>⑪ Exhaust Pipe (1PCS)</p> 	<p>⑫ Binding Ring (1PCS)</p> 	<p>⑬ Angle Protectors (4PCS)</p> 	<p>⑭ Handle (1pcs)</p> 
<p>⑮ Set Screw for Handle (short) (2pcs)</p> 	<p>⑯ Exhaust Fan Stand (4pcs)</p> 	<p>⑰ Exhaust Fan Set (1PCS) (⑧ ⑨ included)</p> 	

SPRAY BOOTH SB-88

Installation Guide

Step 1. Use a screw driver to loosen the screw (8) and remove the Fan cover (9) from (17) exhaust fan set.

Step 2. Bend all the long flaps and short flaps inward according to the indented lines or the direction that the arrow stickers point.

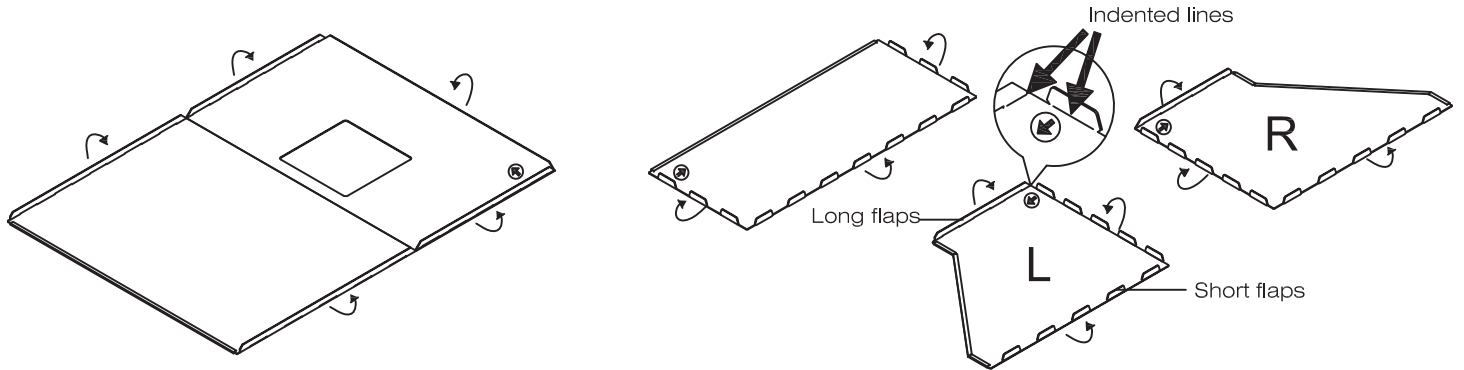

Step 3. Assemble the 4 Booth Sides.

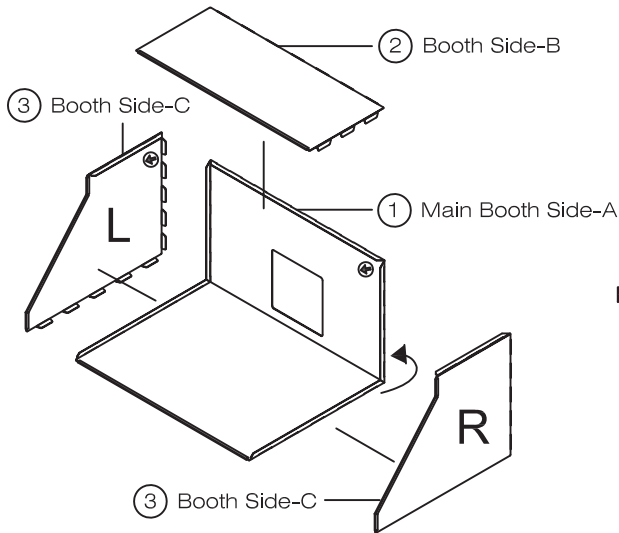

(Before Assembly)

Step 4. When assembling, tuck in Sides (d) of short flaps into the openings of long flaps first. Then press Sides (e) into the openings. Mount the Angle Protectors (13) to the four corners at the front to complete the basic booth assembly.

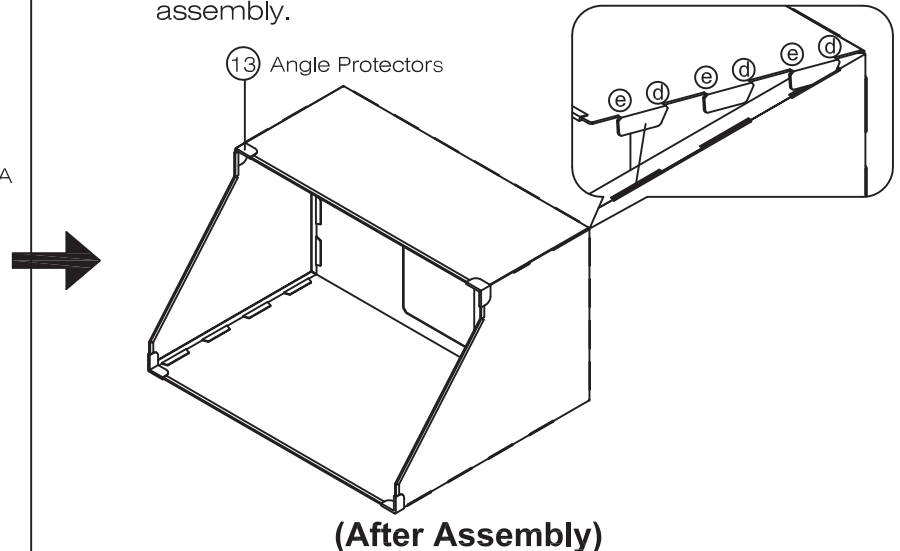

(After Assembly)

Step 5. Screw the Handle (14) onto the top of the Exhaust Fan Set (17) according to the preferred ventilation direction. Wrap the Binding Ring (12) around one end of the Exhaust Pipe (11), and connect the pipe to the Exhaust Fan Set (17) outlet. Use a screw driver to fasten the binding ring (12). Screw in the four Exhaust Fan Stands (16) on the bottom of the Exhaust Fan Set (17).

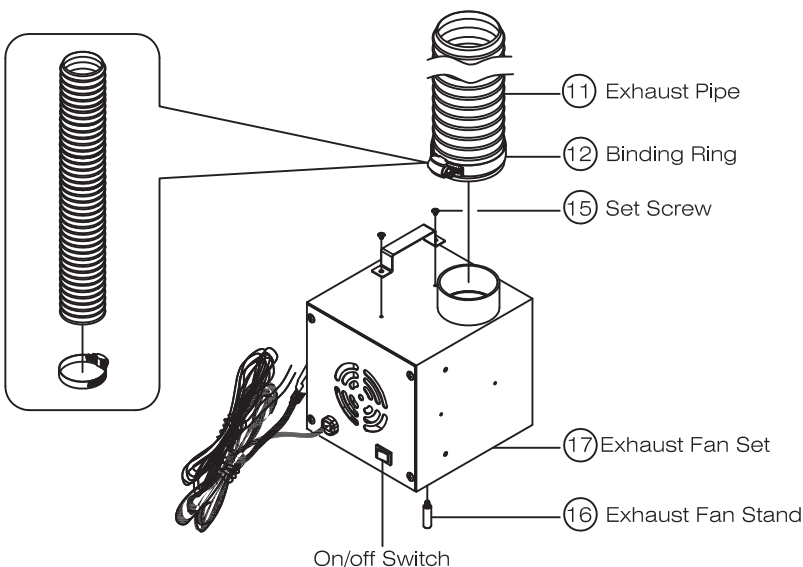

(Before Assembly)

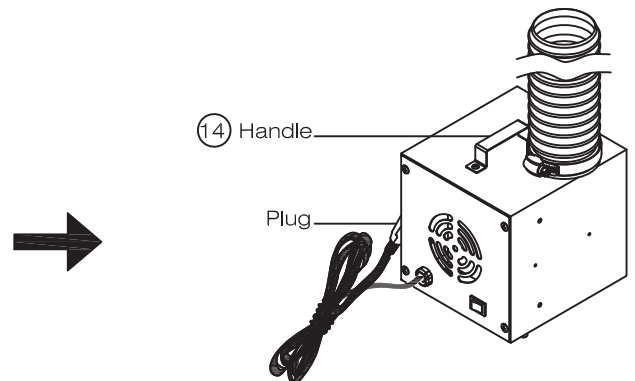

(After Assembly)

SPRAY BOOTH SB-88

Installation Guide

Step 6. Place the Air Intake Hood (4) inside the spray booth. Use a screw driver to secure the Fan Cover (9), the Binding Piece (10) and the Air Intake Hood (4) together onto the Exhaust Fan Set (17) using the four Long set screws (8).

Step 7. Place one Filter 1 (5) & one Filter 2 (6) inside the spray booth, right in front of the Air Intake Hood (4).

Step 8. Place the Rotating Plate (7) at the center of the spray booth.

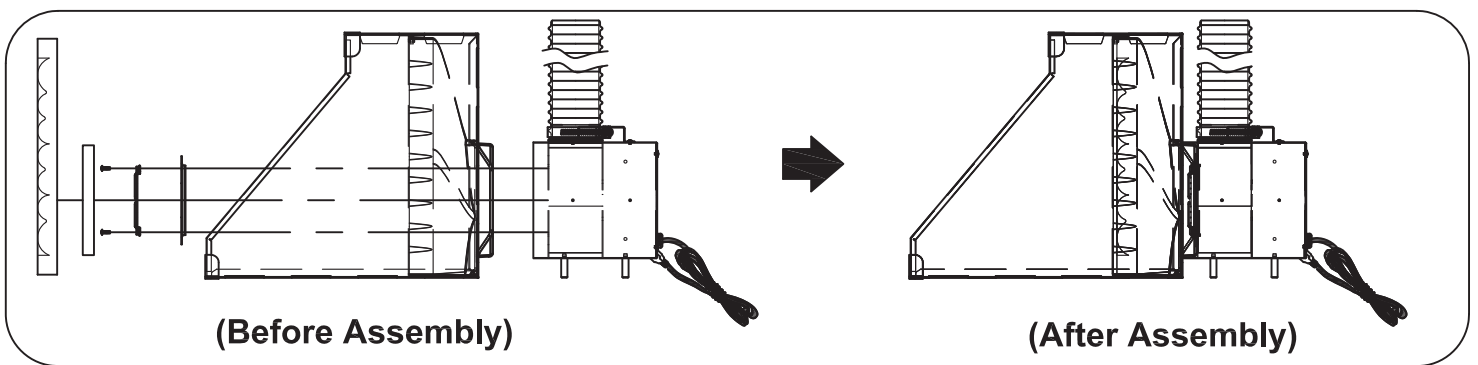
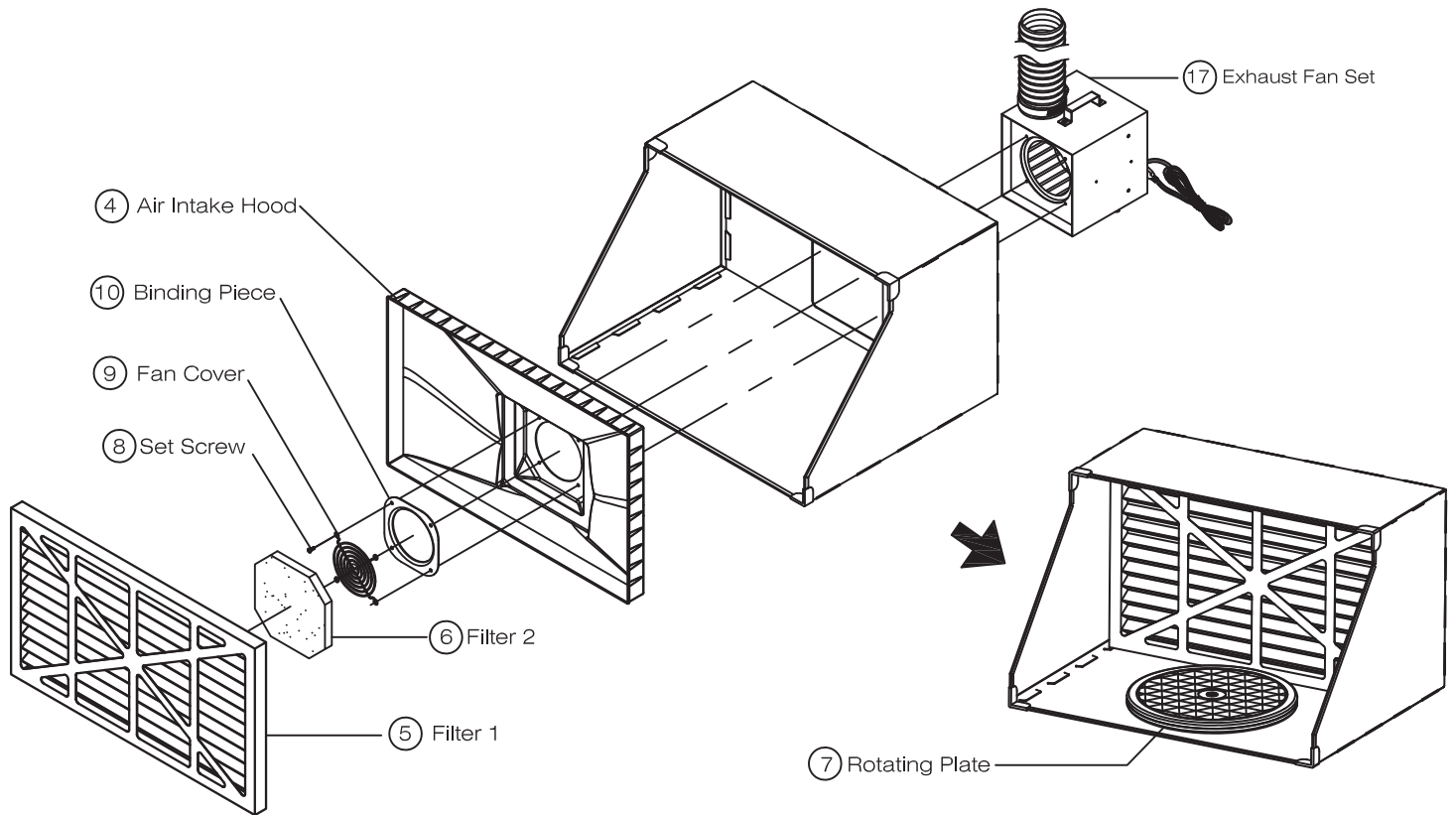

The Handle (14) and the Exhaust Fan Stands (16) are detachable for the convenience of selecting different ventilation outlet directions. Three installation directions are available by turning the Exhaust Fan Set (17) to different sides.

