

MAX-3 / MAX-4

Airbrush Parts

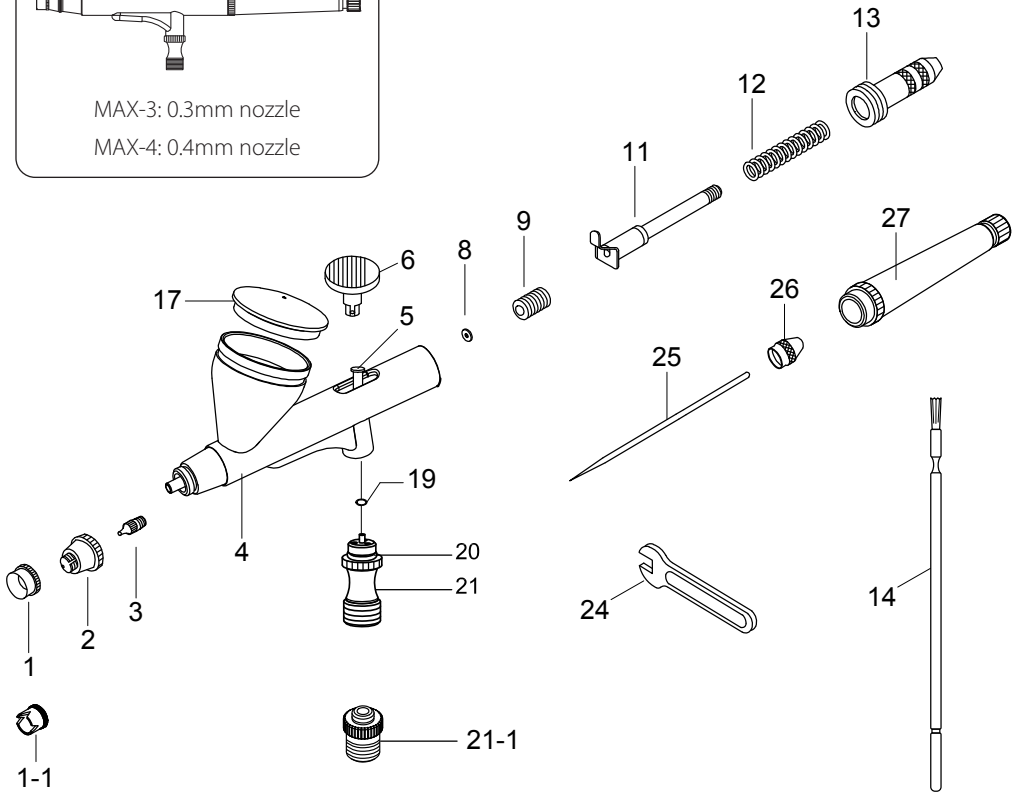
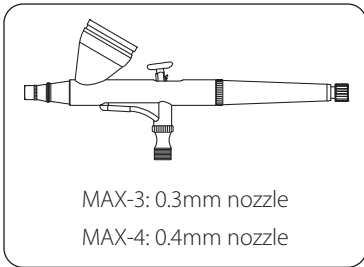

INDEX	DESCRIPTION	INDEX	DESCRIPTION	INDEX	DESCRIPTION
1	Needle cap	11	Needle chucking guide	24	Wrench
1-1	Extra crown-shape needle cap	12	Spring	25	Needle
2	Nozzle cap	13	Spring case	26	Needle chucking nut
3	Nozzle	14	Brush	27	Handle
4	Body	17	7cc cup cover		
5	Piston	19	Piston o-ring		
6	Push button	20	Air valve o-ring		
8	O-ring for needle guide	21	Air valve		
9	Needle guide	21-1	Extra single action air valve set		

WARNING: DO NOT remove the nozzle.

CAUTION: DO NOT allow paints to sit idle in the cup.

CAUTION: Use ONLY airbrush paints and proper airbrush cleaner/thinner.

SET UP & OPERATION

1. Connect 1/8" PS end of hose to the airbrush, the other end to the compressor.
2. Add airbrush paint into the cup, and make sure it is a milky consistency. If not, add proper thinner to dilute.
3. Turn on the compressor.
4. Pre-installed dual action function: press the push button for air only, then pull back for paint. Pull back further for more paint.
5. Single action function: unscrew dual action air valve counterclockwise and install single action air valve set clockwise. Air is released continuously from the airbrush. Pull back the push button for paint.
CAUTION: DO NOT flick the push button or lift your finger before returning to the starting position in front.
6. For closer fine detail work, replace the needle cap with crown cap.

CLEANING

Basic cleaning tips BETWEEN color change and AFTER each session:

1. Mix proper cleaner with remaining paint in cup using the brush.
2. Dump out the mixed solution.
3. Spray cleaner through the airbrush until the spray is clear.

Thorough cleaning as needed:

1. Mix proper cleaner with remaining paint in cup using the brush.
2. Dump out the mixed solution.
3. Block the opening in front of needle cap with a paper towel, add cleaner, press and pull back the push button to create back bubbling. This cleans the entire paint passage.
4. Repeat Step 3 as needed, then spray cleaner through until the spray is clear.

TROUBLE SHOOTING

1. Spidering:

- 1) Paint too thin -> add paint.
- 2) Pressure too high -> reduce pressure.
- 3) Too much paint -> pull back push button less or move airbrush further away from surface.

2. Intermittent spray:

- 1) Clog within airbrush -> clean airbrush thoroughly.
- 2) Paint too thick -> thin paint with proper thinner.
- 3) Pressure too low -> increase pressure.

3. Bubbles in cup:

- 1) Nozzle cap loose -> tighten nozzle cap.
- 2) Nozzle damaged -> replace with new nozzle.

4. Paint doesn't spray:

- 1) Clogged nozzle -> clean nozzle.
- 2) Paint too thick -> thin paint with proper thinner.
- 3) Needle chucking nut loose -> tighten needle chucking nut.
- 4) Pressure too low -> increase pressure.

WARRANTY

Each SPARMAX airbrush is test sprayed and fully inspected to ensure its quality and performance. Warranted for TWO years from date of factory dispatch against workmanship or material defect resulting in inoperable airbrush. Exclude parts subject to wear such as needles, nozzles, o-rings, and damage or loss caused by improper use, unauthorized alteration and negligence.

For any questions or issues, contact the original seller or contact us at info@sparmaxair.com.

SUGGESTED ACCESSORIES

1. Dual head airbrush tool

Replace nozzle with this tool to eliminate overtightening during assembly which damage the nozzle. Include additional function of converting dual action air valve into single action.

2. Cleaning pot

Handy tool for airbrush cleaning without creating a mess in the air. Also include airbrush holder and plastic container for protection which can store small items later on.

3. Airbrush hanger

Different styles to meet the needs of gravity feed, bottom feed, and side feed airbrushes. Available to hold 2, 3 or 4 airbrushes depending on model.

4. QD

Time saving and hassle free tool to switch between multiple airbrushes quickly without screwing and unscrewing the hose. Simply pop and insert.

5. Hoses

Available in straight or curly, PU or braided in different lengths and adaptor sizes (1/8" or 1/4"). Choose the one that fits best!

6. Silver Bullet

Need extra moisture filtering to make sure your masterpiece doesn't get ruined just before completion? This is your last line of defense to capture moisture just before air enters the airbrush. Compressor grade filter with better results.

7. Swivel joint

360° rotation allows you to add as many gadgets as you like between the airbrush and hose, but never form awkward angles or bend the hose which affect airflow.

TIPS & EXERCISES

Basic tips for airbrushing:

1. Always start and end with air only. Adjust the pressure if necessary.
2. With air on, start moving your airbrush, then pull back the push button for color. End by reversing the process, returning the push button to its starting position, but keep air on and continue moving your airbrush.
3. Move the airbrush closer to the surface for thinner/smaller, more concentrated lines/dots, and further away for broader, less defined lines.
4. Between airbrushing breaks, leave the air on to maintain consistent pressure.

Simple airbrushing exercises:

Lines

Use the other hand to hold and stabilize the airbrushing hand. Press for air only, then slowly and steadily move across the paper with your wrist locked. Finish off with air only. Practice drawing thinner and broader lines by varying the distance between the airbrush and the paper.

Dots

Hold the airbrush perpendicular to the paper, press for air only, then pull back the push button a bit and return to its starting position right away with the air still on. Repeat and make dots across the paper. Try connecting the dots with lines.

Shades

Hold airbrush a few inches from the paper, start moving the airbrush with air only, and gently pull back the push button for color from the left of the paper across to the right with constant speed to create even tone, ending with air only. Repeat and try to fill up the paper with even tone throughout, not seeing the start and end.

Dagger Strokes

The goal is to go from wide to a thin point smoothly and gradually. Hold the airbrush away from the paper and start moving with air only, pull back for paint, then simultaneously reduce paint by slowly moving the push button towards its starting position, and move the airbrush gradually towards the paper. This involves moving the arm but not the wrist. Repeat and practice in different directions horizontally, and vertically downwards.